

**Technical Data for RT/1140S & RTT/1140S, RT/1120 & RTT/1120**

Speed:	adjustable from 0 - 120 m/min
Untrimmed product width:	min. 145 mm (5,7"); max. 520 mm (20,47") (min. 110 mm / 4,33" for RT/1120 & RTT/1120)
Trimmed product width:	min. 135 mm (5,31"); max. 500 mm (19,68") (min. 100 mm / 3,93" for RT/1120 & RTT/1120)
Total product stream thickness:	max. 24 mm (0,94") (max. 15 mm / 0,59" for RT/1120 & RTT/1120)
Paper weight:	35 - 140 g/m <sup>2</sup>
Trim per knife:	min. 3 mm (0,118"); max. 55 mm (2,165")
Exhaust power (per pipe):	Air volume: 900 m <sup>3</sup> /h; Depression: 1.960 Pa (N/m <sup>2</sup> ); Air speed: 30 m/s
Power & Voltage:	7 kW (for RT); 14 kW (for RTT); 3 x 400 V AC + PE 50/60 Hz (other on request)
Standard infeed height:	800 mm (31,49") (600 & 1.400 mm / 23,62" & 55,11" for double stream RTT)
Machine length:	1.600 mm (62,99") (1.500 mm / 59,05" for RT/1120 & RTT/1120)

Changes to the technical specification are possible to a limited extent. For complete technical data, see data sheet.

**The right trimmer for each requirement**

Ring knives	segmented knives	Description
RT/1120	RT/1140S	standard trimmer for 1-/2-side trim (1 or 2 knives)
RTT/1120	RTT/1140S	double-stream trimmer for 1-/2-side trim (2 or 4 knives)
RT/4080	RT/4140S	trimming line (trimmer - bump turn - trimmer) for 3-/4-side trim
CT/1090		center cut trimmer - separation trim (1 knife)
CT/2090		center cut trimmer - cut-out trim (2 knives)

**Options:** customizable infeed height, automatic size adjustment

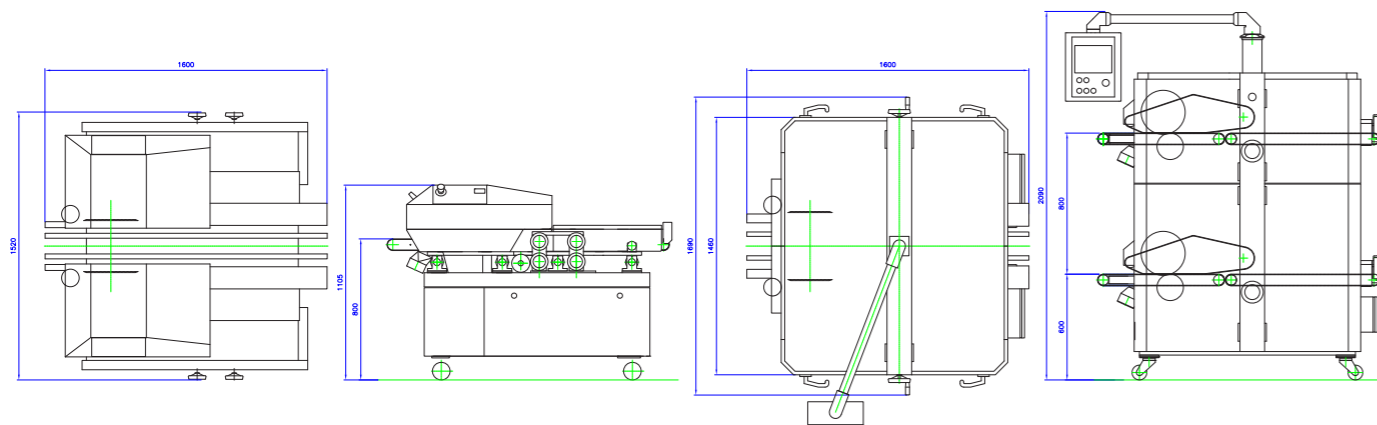

**Always the best trim - we have the trimming solution you need!**



RT/1140S/2140S/4140S & RTT/1140S/2140S  
 RT/1120 /2120 /4080 & RTT/1120 /2120  
 CT/1090 & CT/2090

# Rotary knife trimmers

The ability to trim inline behind a web press makes all the difference - finished products can be delivered of the press and in one step. Trimming requirements for free standing inserts, sales catalogs or newspapers can be very different. The versatility of the RT/1120 and RT/1140 trimmers and their flexible configuration allow you to meet your individual needs and deliver finished products with 1-, 2-, 3- or 4-side trimming.

## Unique benefits

- ▶ Versatility: wide range of trimmers to suit all needs, including single & double stream trimmers, flexible trimming lines, center cut trimmers (separation & cut-out)
- ▶ Trim quality: long stream aligners, safe product control during trimming, choice of ring knives or segmented knives on all trimmers
- ▶ Performance: optimized to run in-line behind the fastest commercial and rotogravure presses
- ▶ Reliability: robust machine construction with high quality components, smooth machine operation with minimized wear and tear
- ▶ Ergonomics: high-resolution touch panel for easy setup & machine operation, self-explanatory error & help messages
- ▶ Automation: easy manual set-up with handwheels or automatic size adjustment with job memory
- ▶ Customization: custom infeed height, with/without vacuum belts, heat-set or cold-set configuration



RT/1140S



RTT/1140S operator interface

The RTT/1140 Double Stream Trimmer is perfectly suited for modern web presses with double delivery. Two superposed shingle streams are trimmed on 3 or 4 sides in a minimal footprint.

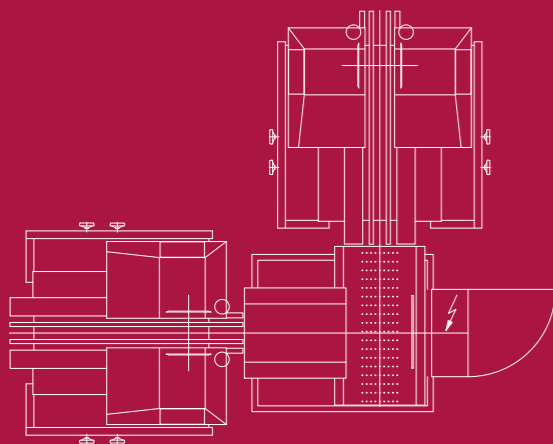

Inserts, newspapers, sales catalogs or even books and magazines - the trimming requirements can be very different. We have been constantly developing the rotary knife technology and today we can offer the most versatile product range. Whether you are looking for a stand-alone trimmer, an all-in-one trimming line, a double stream trimmer or a center cut trimmer - we have the dedicated solution. For best trim quality all our trimmers can be configured with ring knives or with segmented knives - depending on the application and the product specification. The proven trimmers of the RT/1120 family are perfectly suited to the requirements of high-speed retail printing of low-pagination sales catalogs or for the separation of double-digest books while the RT/1140 family will do a great job on higher pagination products or on newspapers. All our trimmers impress with the well-known stable design, state-of-the-art control technology and extremely simple operation.



▶ Whether head/foot, 3- or 4-side trimming, our stand-alone trimmers and all-in-one trimming lines can be configured in a variety of ways to meet specific space constraints and requirements.



▶ For all high-volume presses with two deliveries, the RTT/1140 double stream trimmers are the best solution. Based on the proven technology of the RT/1140 trimmers, the stacked trimming modules allow a space-saving and highly accessible trimming line configuration.

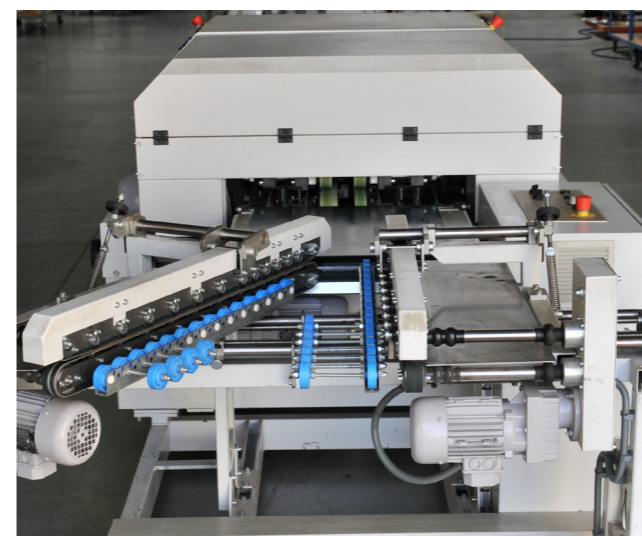

▶ When it comes to product separation the CT/1090 and CT/2090 trimmers are the best choice. The CT/1090 separates the products in the shingled stream with a central cut - perfect for double-digest books that need to be handled separately in the bindery. The CT/2090 is equipped with two knives and separates a product with a central cut-out into two finished products - perfect for retail products.



▶ Make your choice: All our trimmers can be configured with adjustable ring knives or with segmented knives. Ring knives are best suited for lower paginations and products with a lower paper weight. Segmented knives are better suited for higher page counts and thicker paper.