

Technical Data

Product orientation:	spine leading at infeed
Performance:	up to 135.000 copies/hour (product permitting)
Product format L x W:	min. 110 x 145 mm (4,33" x 5,7") max. 325 x 500 mm (12,79" x 19,68") Shingle gap: 30-80 mm (1,18"-3,14") Shingle stream thickness: up to 30 mm (1,18")
Page count:	4 - 128 pages (@ 60 g/m ²)
Paper weight:	35 - 140 g/m ²
Height upper bin:	max. 180 mm (7,08")
Stack height:	CS/3160 & CS/4160: 30 - 300 mm (1,18"-11,81") CS/5160 & CS/6160: 30 - 400 mm (1,18"-15,74")
Infeed height:	Low infeed: 700 - 1.100 mm (27,55"-43,3") (CS/5160 & 6160: + 100 mm / 3,93" height) High infeed: 1.100 - 1.700 mm (43,3"-66,92")
Delivery height:	850 mm (33,46")
Power & Voltage:	4 kW, 3 x 400 V AC + N + PE 50/60 Hz (other on request)
Color:	Light grey, RAL 7035
Weight:	~ 1.200 kg (2645,54 lbs)

Changes to the technical specification are possible to a limited extent. For complete technical data, see data sheet.

One stacker for all applications

Base models	Stack height max.	Infeed height		Optional Straight-out delivery
		Low infeed	High infeed	
CS/3160	300 mm (11,81")	F	H	S
CS/4160 (for newspaper)	300 mm (11,81")	F	H	S
CS/5160	400 mm (15,74")	F	H	S
CS/6160 (for newspaper)	400 mm (15,74")	F	H	S

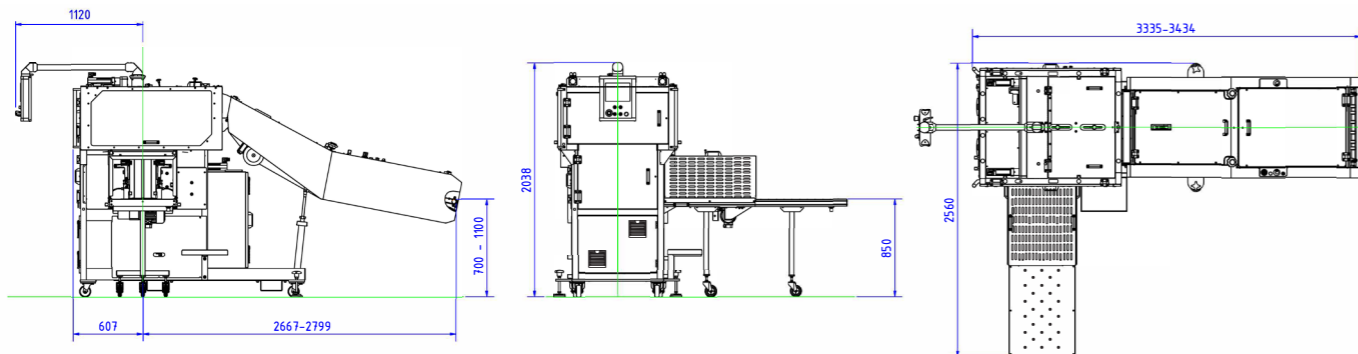

Stacking at its best - redefining performance & reliability!



Lift stacking



The Merten Group is a stable, family-owned company that operates in three business areas: precision engineering, mechanical engineering and Postpress. We have been in the market for over 100 years and are running the business in the 5th generation.



Postpress | Service & Support | Rebuilds | Relocations | Special Solutions

HQ Austria: Fon: +43 1 2594648 | mail: mm-office@merten.at
Germany: Fon: +49 8171 404 0 | mail: customerservice@gammerler.de

www.inlog-gammerler.com

CS/3160
CS/4160
CS/5160
CS/6160



Compensating stacker CS/3160

Good bundle quality and trouble-free stacking are typical requirements of commercial and newspaper printers. The CS/3160 reliably converts the shingled stream into high-quality bundles. Two sets of servo-controlled lifts, controlled by a closed-loop system, ensure continuous stacking with virtually no drop height and minimized risk of jams. Because needs vary, the CS/3160 can also be configured as the CS/4160, CS/5160, CS/6160 to accommodate different stack heights, high or standard infeed, and cold or heat set operations.

Unique benefits

- ▶ Performance: optimized for the fastest retail presses, but also perfect for use behind newspaper presses or saddle stitching drums
- ▶ Reliability: sturdy machine construction with high quality components, smooth machine operation with minimized wear and tear
- ▶ Ergonomics: high-resolution touch panel for easy setup & machine operation, self-explanatory error & help messages
- ▶ Productivity: fast & automated size changeover, job memory, intelligent interface for production management and job control. Optional connectivity to ERP-system
- ▶ Operator-friendly: transparent covers, large doors with direct access to the machine, highest safety standards
- ▶ Versatility: Unique flexibility in commercial and newspaper printing thanks to modular configuration of 16 versions (bundle height, infeed, pusher, commercial/newspaper,...)



7" Touch-Color-Display with 270° swivelling commander

The Gämmerler KL 540/560 compensating stackers have long been the standards in stacking. The CS/3160 takes the strengths of stacking quality, reliability and mechanical engineering of the KL stackers and combines them with improved ergonomics, simpler operation and future-proof programming.

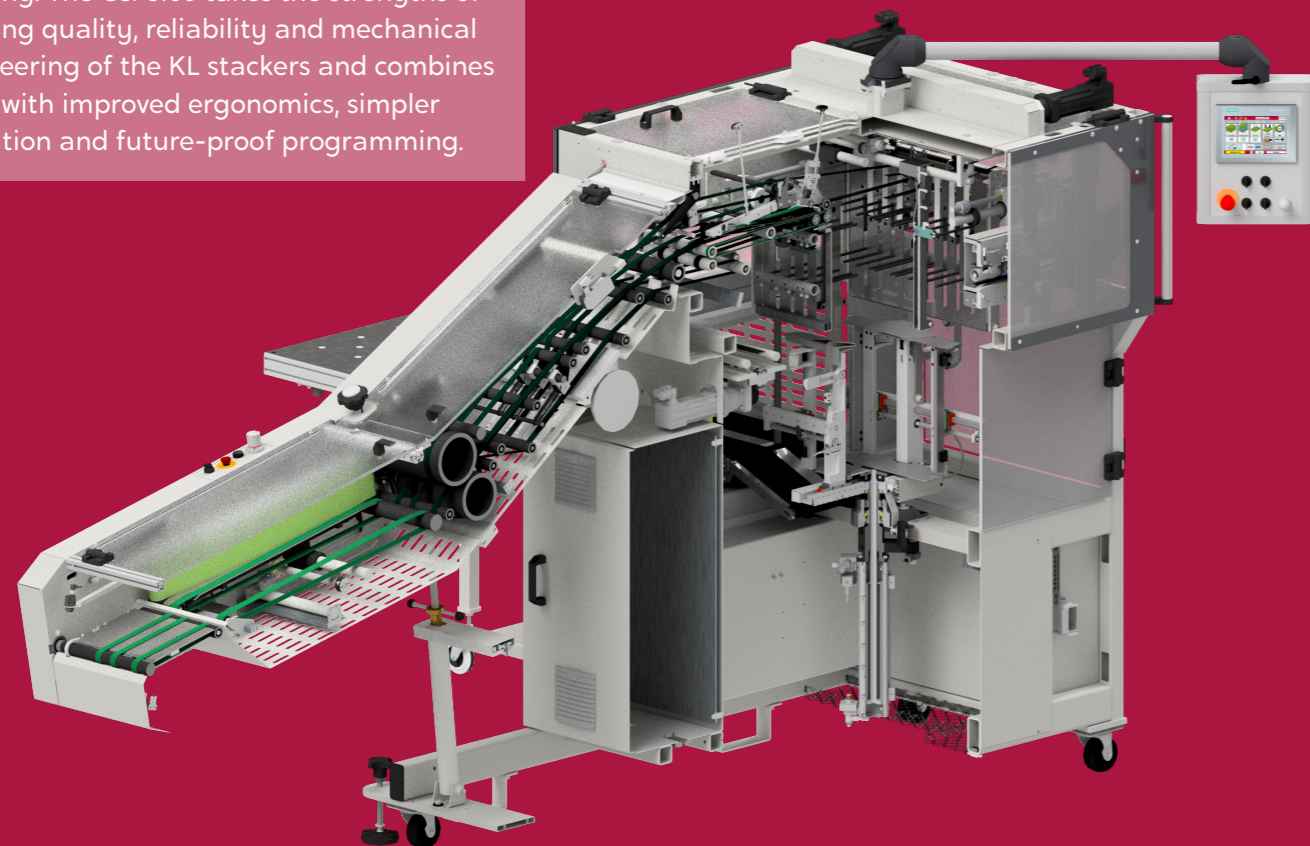

Inserts, newspapers, magazines or books - the stacking requirements can be very different. The CS/3160 is the standard for compensating stacking behind high-speed / high-volume presses. It is the consistent improvement of the very successful Gämmerler compensating stackers KL 540 / KL 560. The proven Liftpack system ensures a smooth and continuous stacking process and is perfectly suited to the requirements of high-speed retail printing of low-pagination sales catalogs. In addition to its high performance, the CS/3160 impresses with its unique accessibility, the well-known stable design, state-of-the-art control technology and extremely simple operation. The modular design of the CS/3160 allows 16 different versions to meet the needs of insert and magazine printing, short-run book printing and direct newspaper printing.

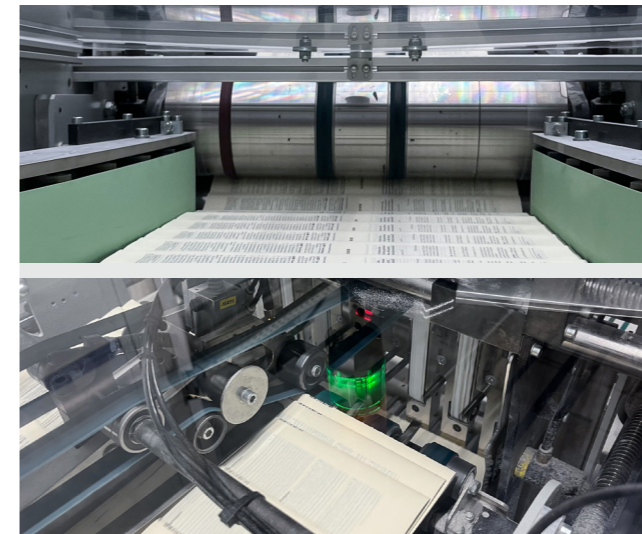

▲ Bundle quality starts at the infeed: long side joggers, large squeeze rollers and a high-performance separator for a reliable gap building, especially at high speeds and with thin paper. This results in fewer jams, less waste & more productivity!

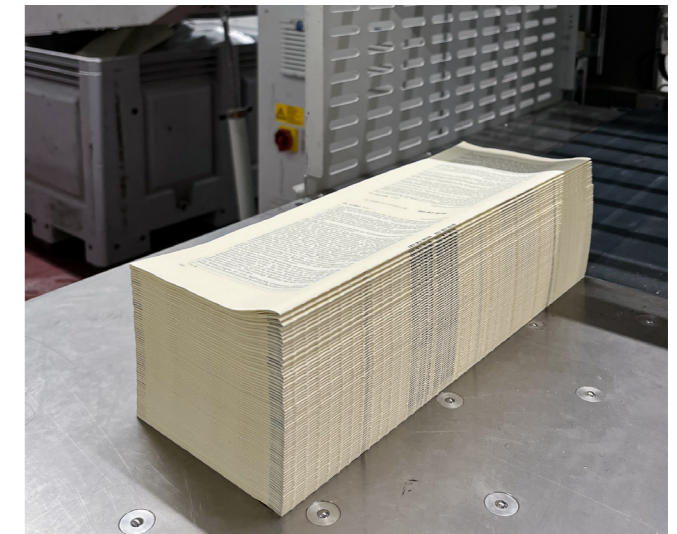

▲ The lift technology with synchronous fork movements ensures reliable stacks, even with difficult formats and papers. Smooth, servo-controlled stacking increases productivity by minimizing the risk of jams and reducing operator fatigue.

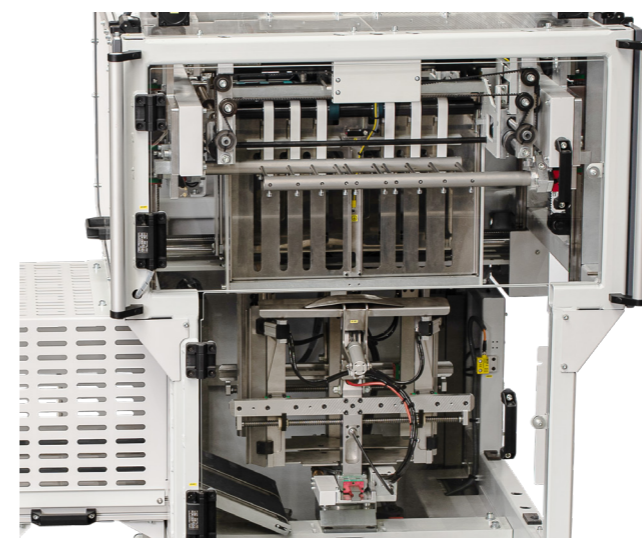

▲ Maximum production reliability: clarity and transparency through large door and cover panels, e.g. in the crusher, upper bin and turntable areas. The operator benefits from easier monitoring, safer action and faster troubleshooting!

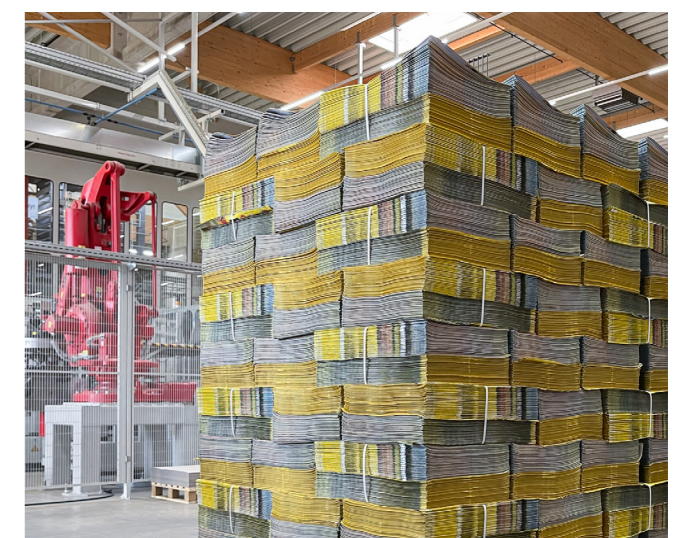

▲ The result is impressive: precisely aligned and compensated stacks will result in high-quality pallets, especially in an automated palletizing process. Perfect pallets mean safe pallet transport without damaged copies and higher productivity on the inserting lines.