

Technical Data	
Product orientation:	depending on product / infeed
Cycle time:	max. 8 cycles / minute (excl. slipsheet, excl. pallet change)
Products:	bundles (loose, strapped, film-wrapped), boxes, mini-logs, cartons, ...
Infeed:	accumulation conveyors & pick-up, slip-torque conveyors, roller conveyor
Gripper types:	mechanical gripper, vacuum gripper, log gripper, ...
Product format:	bundles: approx. A5 - A4 (other on request) boxes: approx. A4 - A3 (other on request)
Bundle height:	min. 50 mm (1,96") (pressed); max. 300 mm (11,81")
Bundle weight:	max. 25 kg (55,11 lbs)
Product format (logs):	min. 145 x 145 mm (5,7"x5,7"); max. 330 x 240 mm (12,99"x9,44")
Log length:	max. 600 mm (23,62") (product permitting) (optinal: 800 mm / 31,49")
Log weight:	max. 50 kg (110,23 lbs)
Palletizing height:	up to 1.550 mm (61,02") (incl. pallet)
Palette size:	800 x 1.200 mm (31,5"x48"), Optional: up to 1.200 x 1.200 mm (48"x48")
Slipsheet (optional):	min. 970 x 680 mm (38,18"x26,77"); max. 1.200 x 800 mm (47,24"x31,49")
Infeed height:	850 - 900 mm (33,46"-35,43")
Voltage:	7 - 15 kW, 3 x 400 V AC + N + PE 50/60 Hz (other on request)
Color:	Light grey, RAL 7035

Changes to the technical specification are possible to a limited extent. For complete technical data, see data sheet.

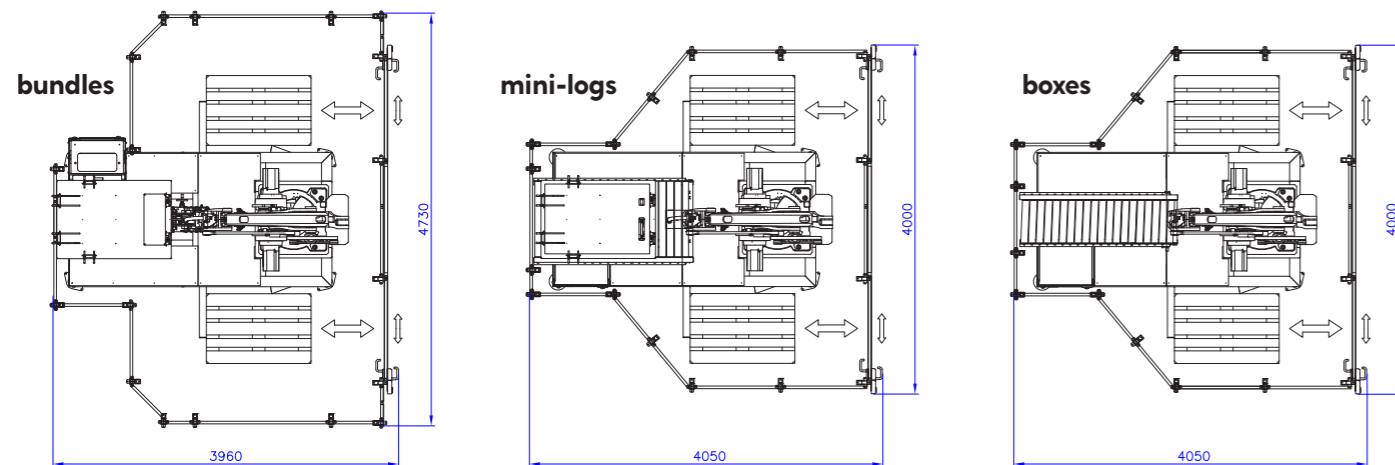

ERIC - flexible, powerful & movable mini-robot

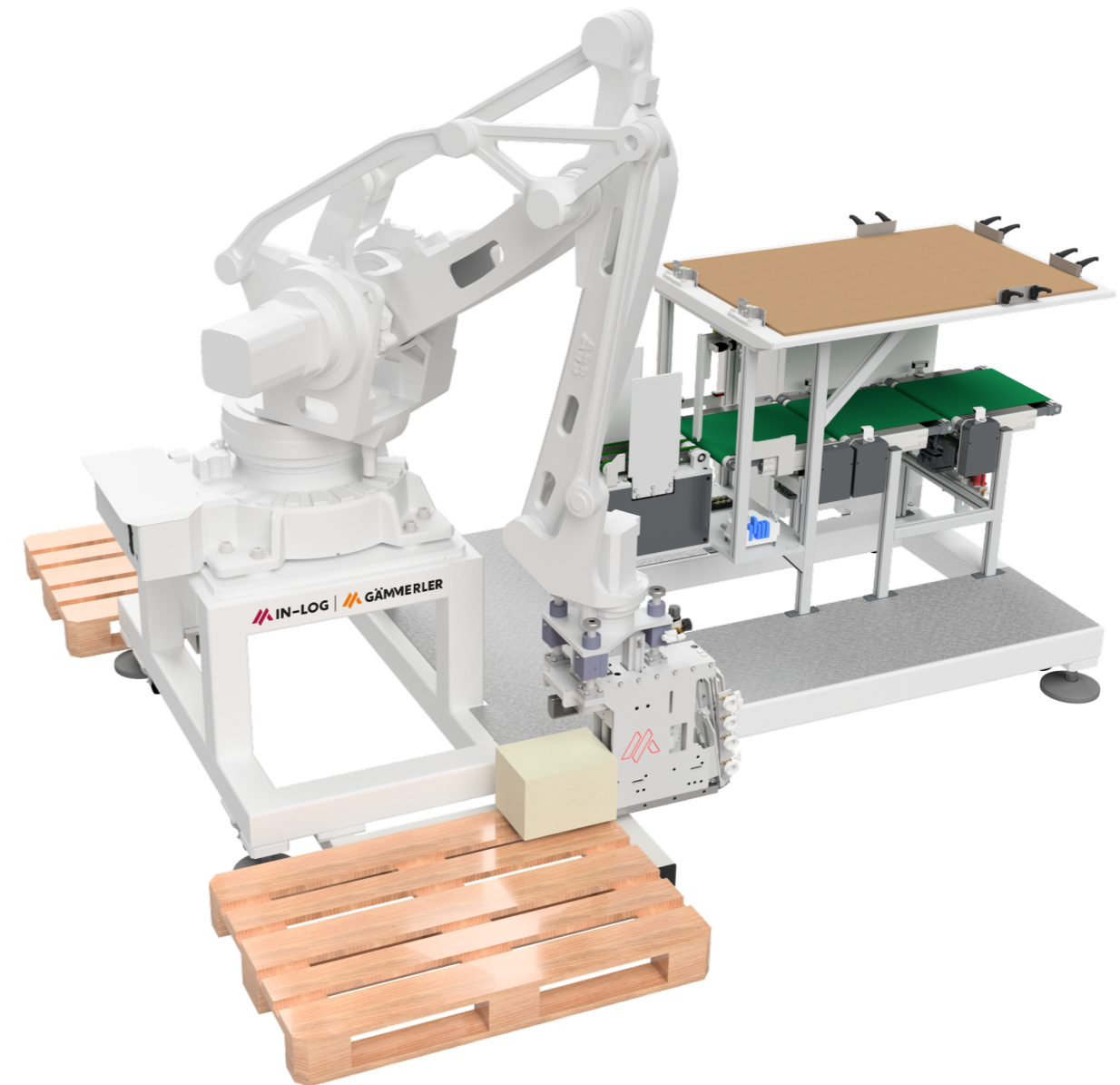

Mini-robot | end-of-line palletizing

It is becoming increasingly difficult to find workers for monotonous tasks such as manual palletizing. For high-speed, high-volume systems, robots have proven to be the way to go. But what is the best solution for lines with slower speed, where space is limited and ROI is more difficult to calculate because the equipment is not running 24/7? ERIC, our new mini-robot, could be the answer - it combines all the above requirements into an industrial solution at an attractive price. Because end-of-line palletizing can vary, ERIC is designed as a modular system. Infeed, gripper type, number of pallets - your application defines the final configuration.

Unique benefits

- ▶ Unique reliability based on a proven industrial robot and standard palletizing software
- ▶ Highly flexible configurations
 - ▷ Infeed with bundle conveyor, rollers, slip torque (other on request)
 - ▷ Single/double grippers, log gripper, vacuum gripper (other on request)
 - ▷ One or two palletizing places (for back-up or alternating palletizing)
- ▶ Fast - max. 8 cycles / minute
- ▶ Strong - max. loads up to 110 kg for heavy boxes and mini-logs
- ▶ Impressive reach - up to 2.500 mm for two 48"x48" pallets
- ▶ Movable - can easily (1-2 persons) be moved between lines
- ▶ Easy to use - predefined palletizing patterns, easy to recall and execute
- ▶ Options: slip sheet feeder, palletizing of A/B productions

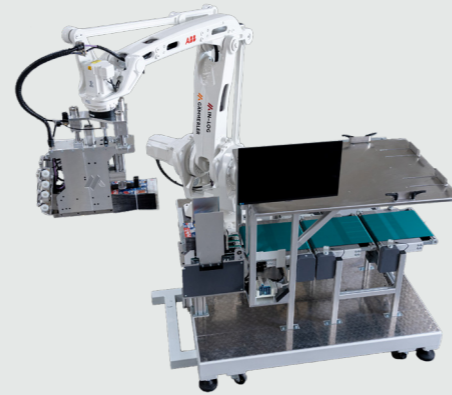

ERIC can be configured in several combinations with:

- ▶ different infeeds
- ▶ different grippers
- ▶ 1 or 2 pallets

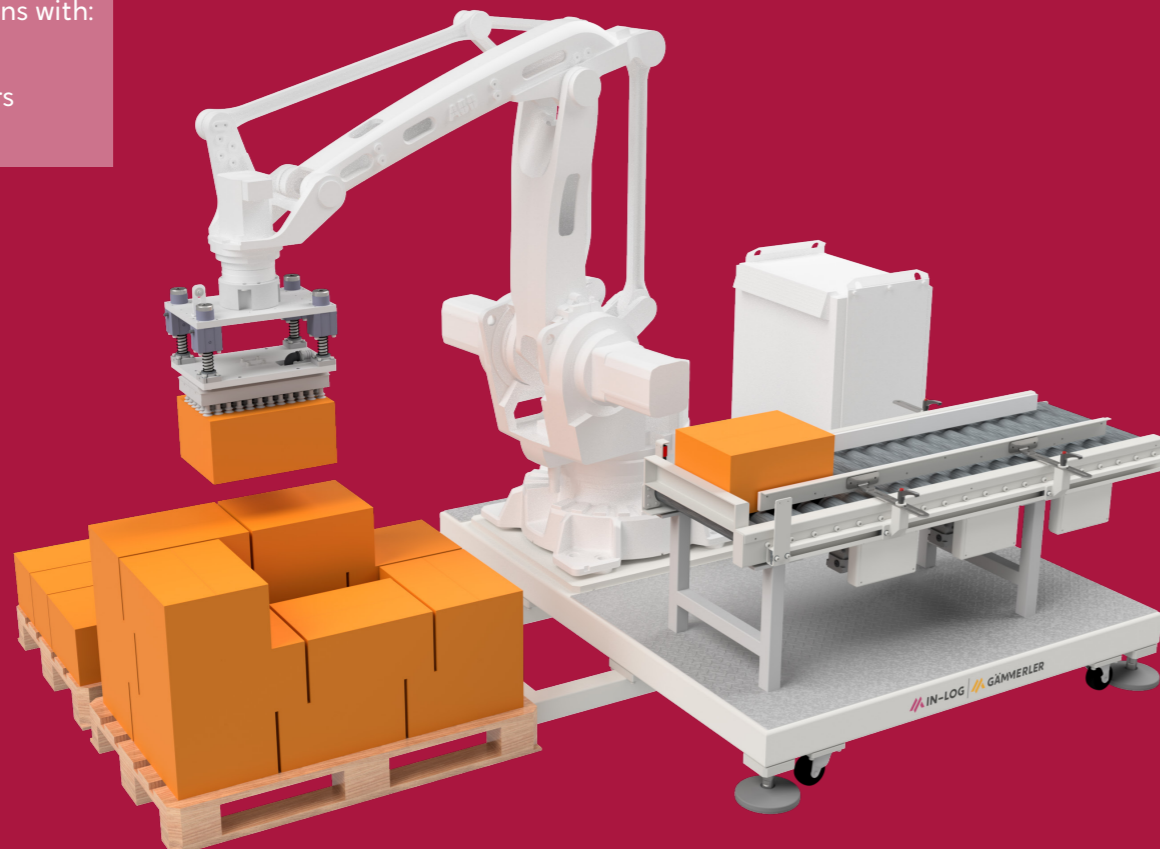

Slower presses delivering bundles or short logs, slower bookbinding lines, cartoning lines, etc. - in many places we still use manual palletizing because we lack efficient solutions for these requirements. Budget, limited floor space, utilization are just three of the challenges for an end-of-line automation solution in these areas. While cobots are a great solution for many automation tasks, in our industries they are most often used as robots - that is, with a safety fence. The speed required - even on slower lines - can be a challenge for a cobot, as can the load and reach. ERIC, our mini-robot, cannot be used as a cobot, but its speed, load and reach are more suited to the requirements we face. However, ERIC is mobile, requires very little floor space, and is a proven and reliable solution. In many applications, the benefits will outweigh the limitations.

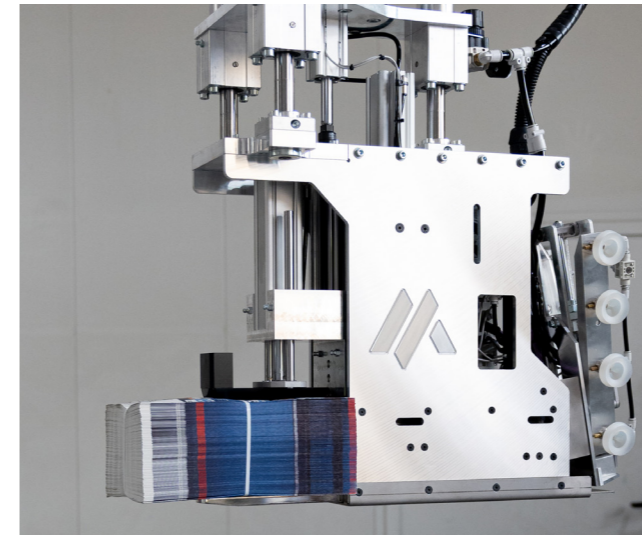

▲ Handles loose, strapped, and film-wrapped bundles, up to 400 bundles/hour. The single gripper is just one of several ways to configure the ERIC mini-robot. The optional rear-mounted slip sheet gripper allows slip sheets to be placed onto defined layers.



▲ All-in-one and mobile! ERIC is built on a frame that integrates the robot arm, the infeed and an optional slip sheet table. Two operators can easily move the mini-robot between different lines and use it where it makes the most sense.

